

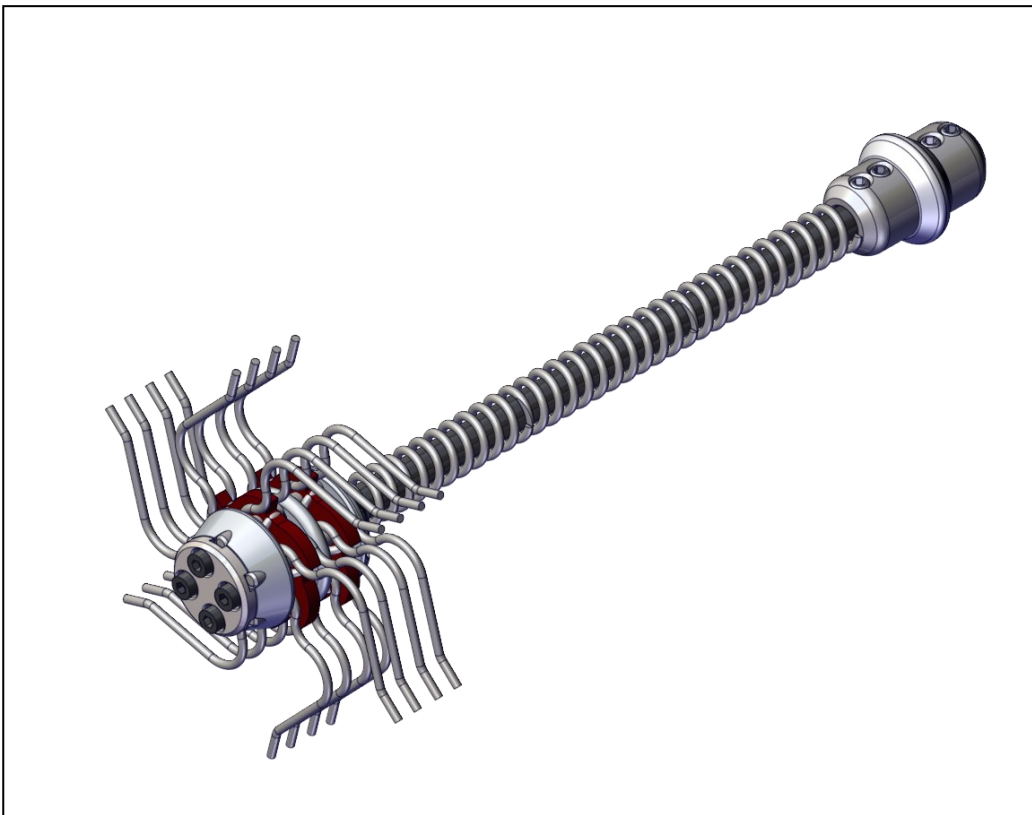

## Operating & Safety Manual

Smart Spider DN100 (4") & DN150 (6")



### **WARNING**

These instructions are for your personal safety. Always ensure that you have read and understood these instructions before using any tools of the Smart Spider range. Please also read and understand the corresponding Miller manual before using the Mini Sweeper tool.



We now have resellers in the U.S., Europe & Australasia.

Locate your reseller at [picotesolutions.com](http://picotesolutions.com)

# TABLE OF CONTENTS

TOPIC	PAGE/S
SAFETY INFORMATION & SYMBOLS	3
AVAILABLE SIZES & POWER SOURCES	5
RANGE, ASSEMBLY & USE	6
MAINTENANCE & SPARE PARTS	13
PRACTICAL TIPS & SAFETY ADVICE	14
WARRANTY POLICY & PROCEDURE	15

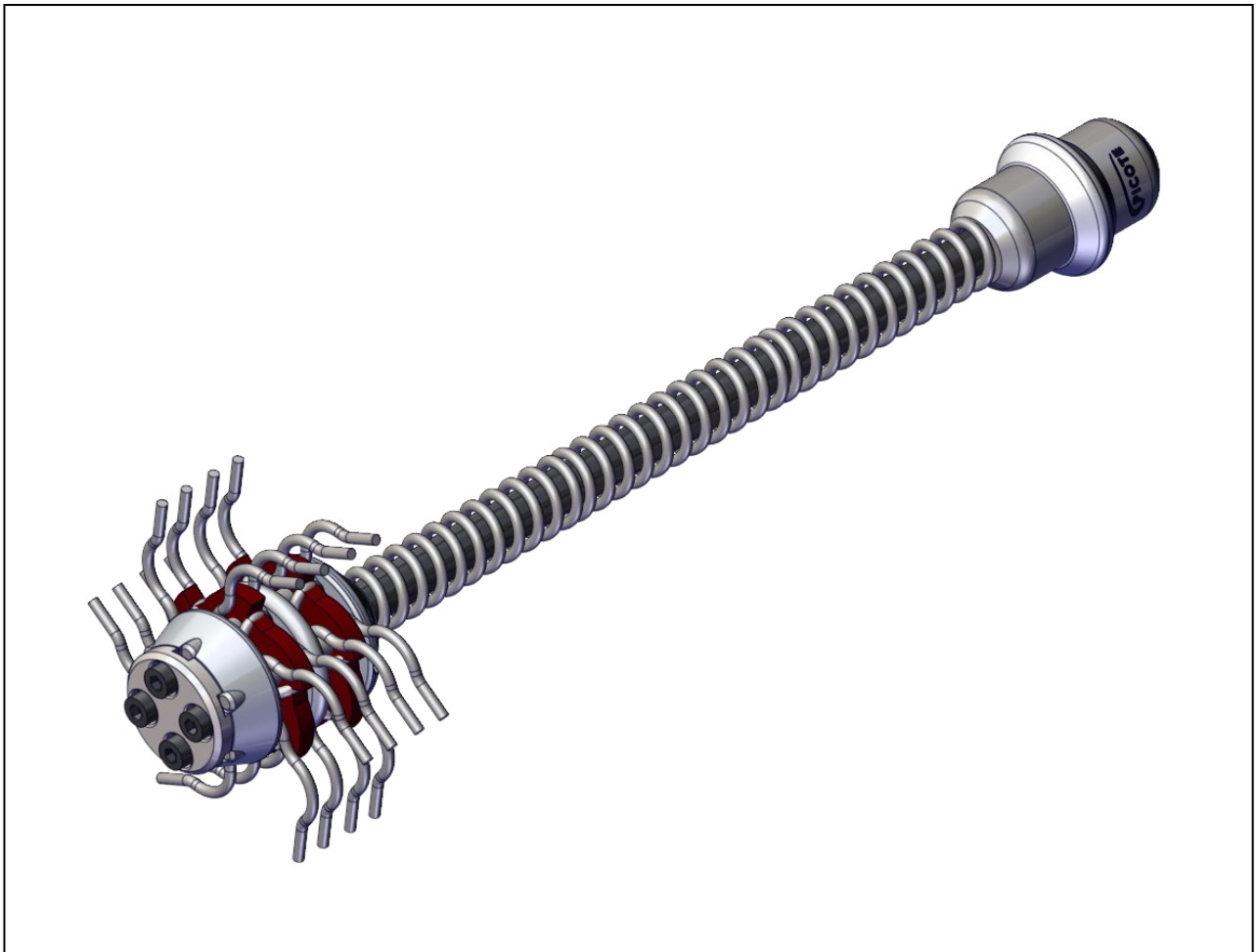

To watch practical demonstration videos, or to download an electronic copy of these Instructions, please visit [www.picotesolutions.com](http://www.picotesolutions.com). Please note that videos are not intended as a replacement or alternative to this operating and safety manual, but only as an additional learning tool.

## SAFETY INFORMATION

### **WARNING**

*This section contains important safety information. Failure to comply could result in serious injury or death.*

### Safety Symbols

Safety symbols are used throughout this manual to draw attention to potential hazards.



**Danger** risk of serious injury, follow instructions.



**Danger** risk of serious injury from rotating parts, follow instructions.

### Personal Protective Equipment (PPE)

Always use Personal Protective Equipment when using the Smart Spider, including suitable overalls / protective clothing & footwear and the following:



Always wear suitable eye protection when using the Smart Spider to prevent dust from irritating your eyes.



Always wear suitable ear protection when using the Smart Spider to prevent any hearing loss.



Always wear suitable cut-resistant gloves when using the Smart Spider to prevent any hand injuries. Any open injuries or skin irritations should be covered at all times to avoid contact with sewage, chemicals or dust.



Always wear a suitable respirator when using the Smart Spider to prevent any resin dust or fumes from pipes being inhaled or consumed, which can cause occupational asthma or dermatitis as well as eye irritation.

### Always remember



Dust produced can be dangerous to your health, inflammable or explosive.

Make sure the pipe has been **opened** and **ventilated** to stop any gases forming in the lateral pipe where the work takes place.

Before assembly, use, replacement of parts or maintenance, unplug the Picote milling machine. **Failure to comply may lead to serious injury including electric shock or injury from rotating parts!**

## SAVE ALL WARNINGS AND INSTRUCTIONS FOR FUTURE REFERENCE

**⚠ WARNING** *This section contains important safety information. Failure to comply could result in serious injury or death.*

### ENVIRONMENTAL

**Operational Ambient Temperature Range:** -10...50 °C (14...122 °F) frost and condensation free

**Storage Ambient Temperature Range:** -20...60 °C (-4...140 °F) frost and condensation free

### TRANSPORT

Picote tools should be transported in car or other vehicle properly secured to prevent any sudden movements caused by hard braking or accident. Using lidded boxes which are fastened and stored on the bottom of a van is recommended.

Never transport machine with tool attached to the shaft.

If using pick-up or trailer to transport Picote machine or tools, cover the products to protect them from raining water and dust.

### STORAGE

It is recommended that tools are stored indoors protected from rain and sunlight and in constant ambient temperature.

Clean used Spider with fresh water after taken out from the pipe. Store in place where tools can dry out properly. Water exposure and attached dirt expose Spider to rust.

### DISPOSAL

Smart Spider metallic and plastic components can be separated and disposed separately as plastic and metal waste.

Always follow the local waste handling rules and regulation.

## AVAILABLE SIZES & POWER SOURCES

The Smart Spider is a special tool for cleaning fragile or damaged pipes. The Smart Spider can go through pipes where sections of the pipe are missing, without getting stuck. As the tool rotates the Smart Spider legs adapt to the diameter of the pipe. The Smart Spider can also be used also in plastic pipes, however, it must be used with extra care.

### Choosing the correct Smart SPider for the job

Select the correct Smart Spider according to the size of the host pipe.

Place the tool completely inside the pipe before powering up the tool.

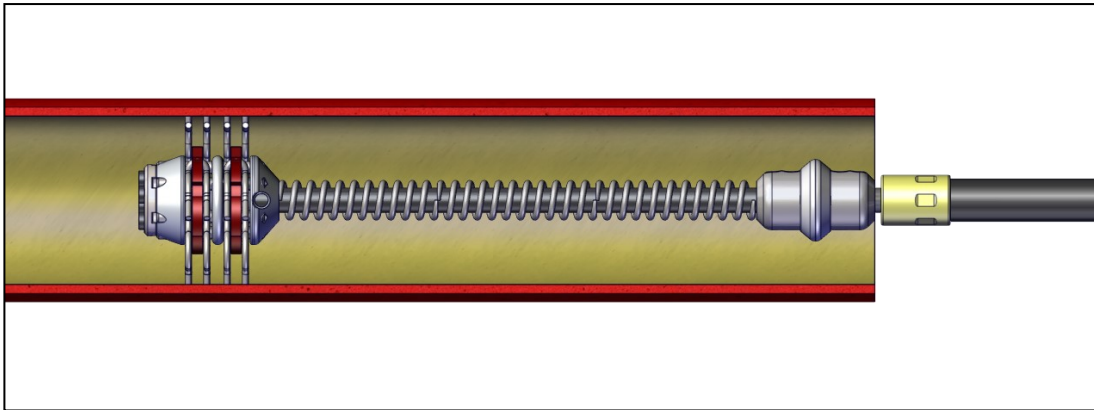

**! WARNING**



SMART SPIDER	Shaft size mm/inches	BEND 90°	BEND 45°
Smart Spider DN100 (4")	12 (1/2")	YES	YES
Smart Spider DN150 (6")	12 (1/2")	YES	YES

### CHOOSING YOUR POWER SOURCE

The Smart Spider DN100 (4") and DN150 (6") with the 12mm (1/2") diameter shaft can be operated with the **Picote Midi & Maxi Miller** machines.

The Smart Spider+ products with the 18mm (3/4") diameter shaft can **ONLY** be operated with **Maxi Miller Power+**. The Smart Spider+ tools have their own manual.

# SMART SPIDER RANGE, ASSEMBLY & USE



Please read safety information on page 3 before assembly and use.

Smart Spider DN100 (4")

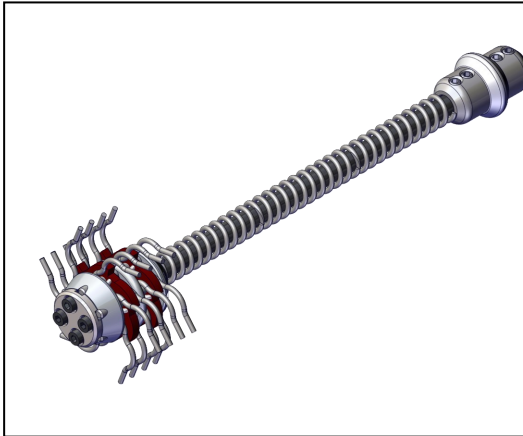

Smart Spider DN150 (6")

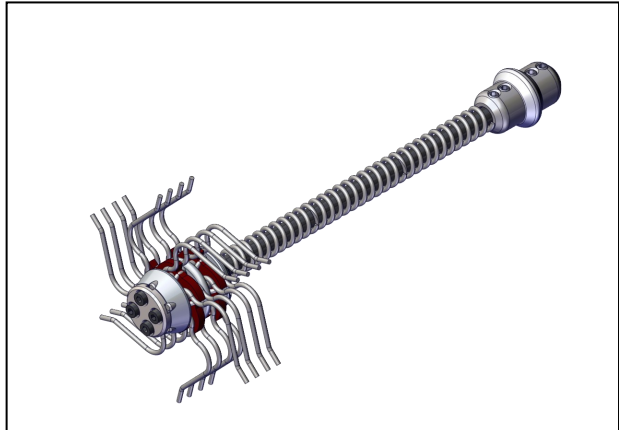

Smart Spider DN100 (4") & DN150 (6") with carbides—AVAILABLE SOON

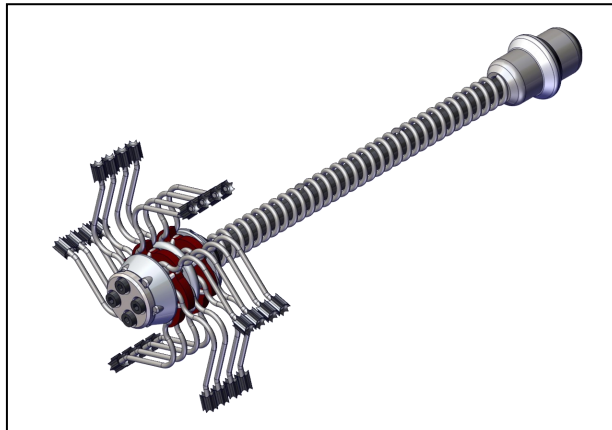

1390125102	Smart Spider DN100 (4")
1390125152	Smart Spider DN150 (6")

## Tool Change—Smart Spider DN100 (4") & DN150 (6")

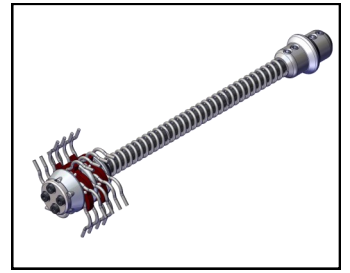

**Step 1.** Remove the Set Screws.

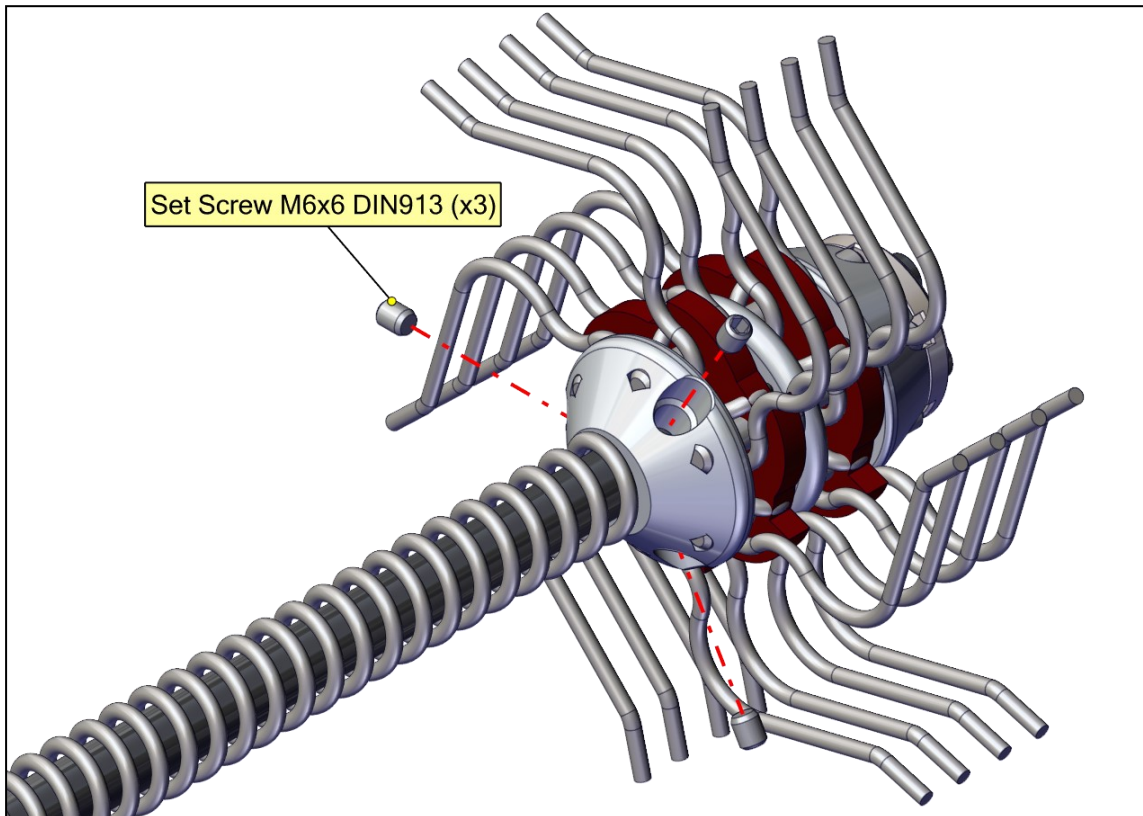

**Step 2.** Remove the Allen Bolts, Spring Washers and Hub Disc.

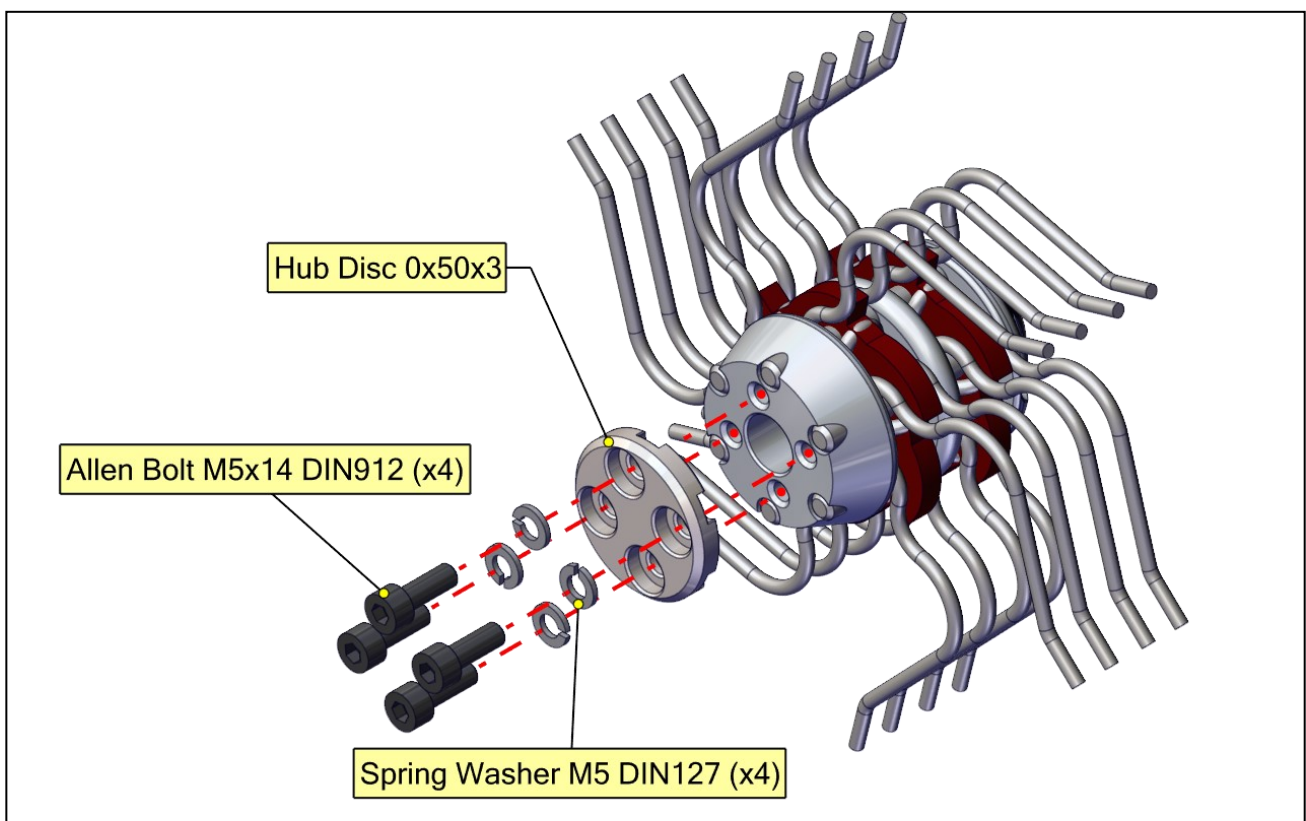

**Tool Change—Smart Spider DN100 (4”) & DN150 (6”)**



**Step 3.** Pull out Spider Axles. Remove worn Spider Legs and Premium Rubber Flexes.

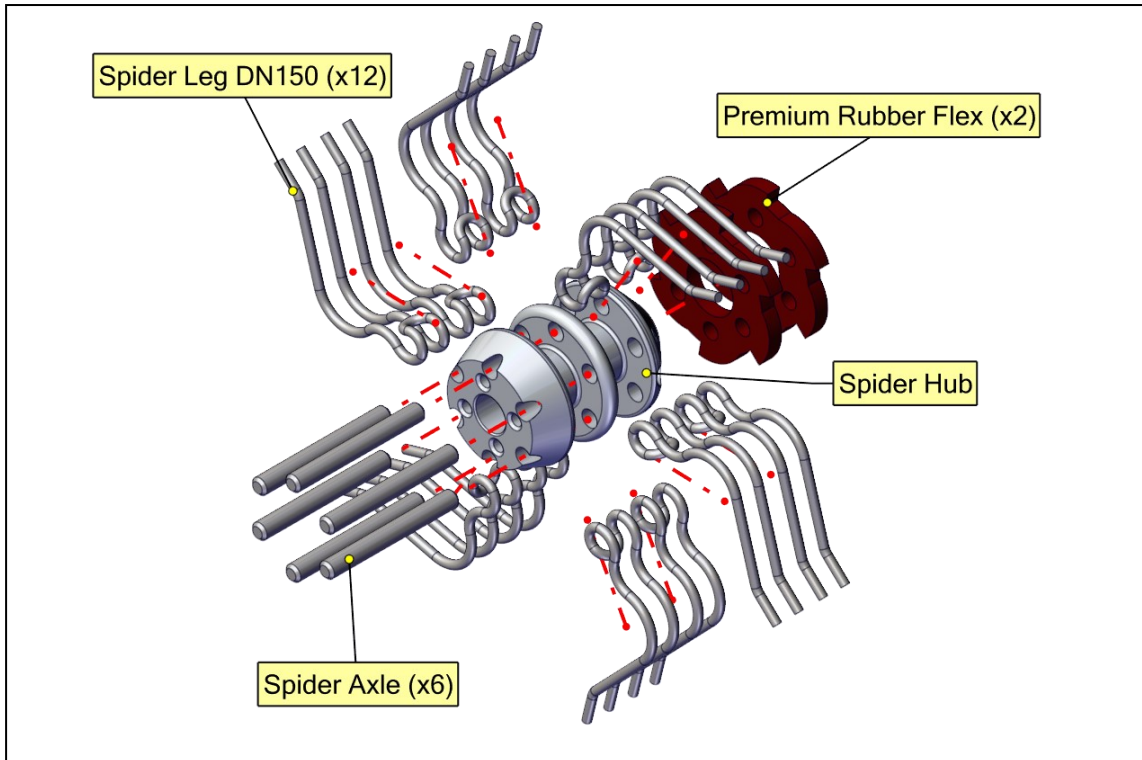
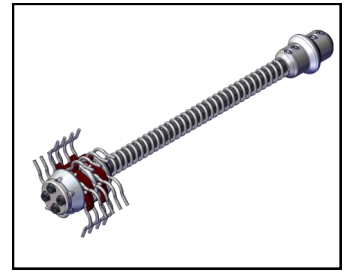

**Step 4.** Push the new Premium Rubber Flexes to the Hub. The Rubber Flexes are pre-cut to assist the change procedure.

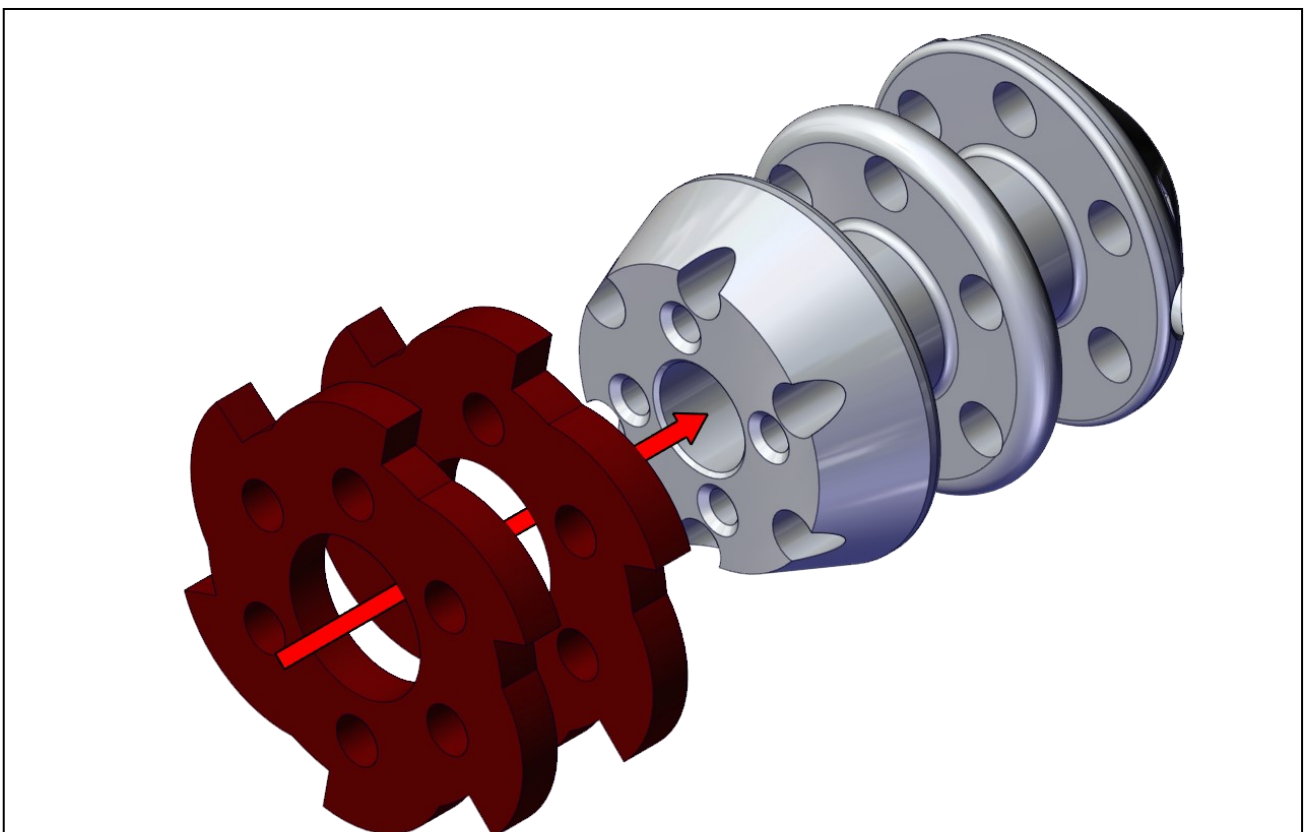



Tool Change—Smart Spider DN100 (4") & DN150 (6")



**Step 5.** Replace the Spider legs in pairs. Make sure that the legs are fitted properly. Look at the correct position on Step 6.

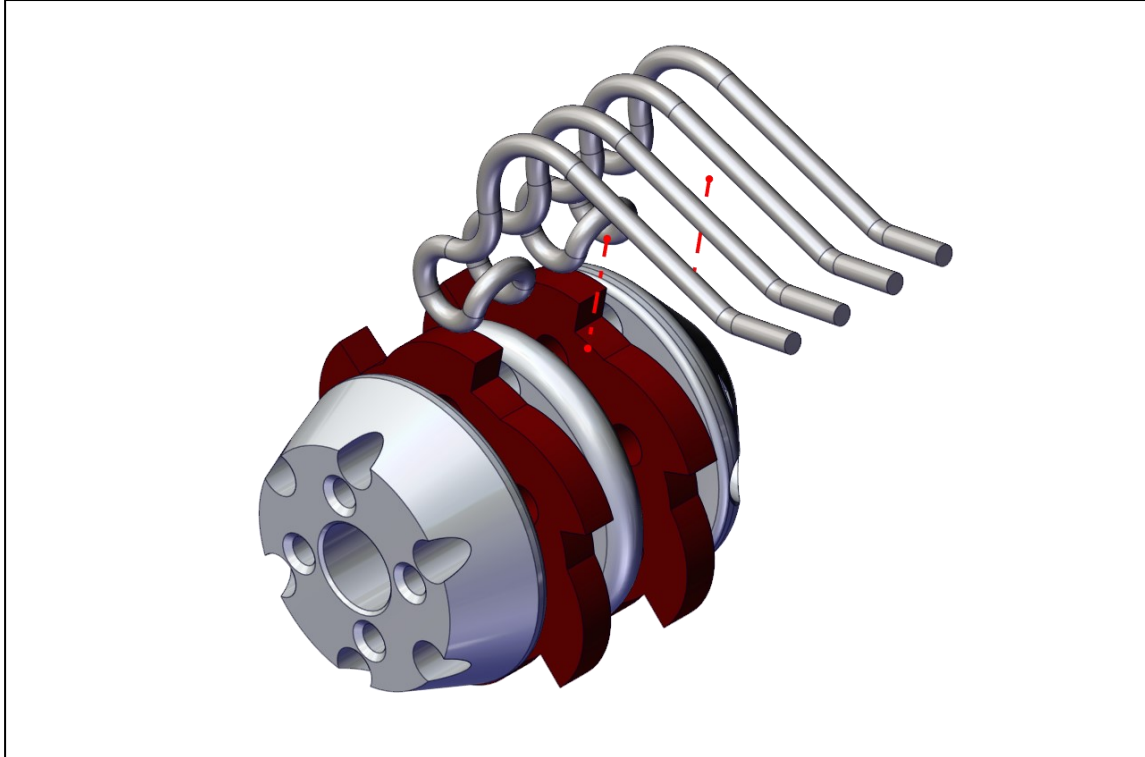
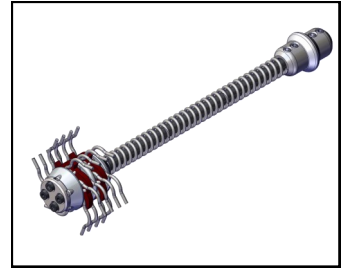

**Step 6.** Use Spider Axle to lock the Premium Rubber Flex and Spider Leg to the Hub.

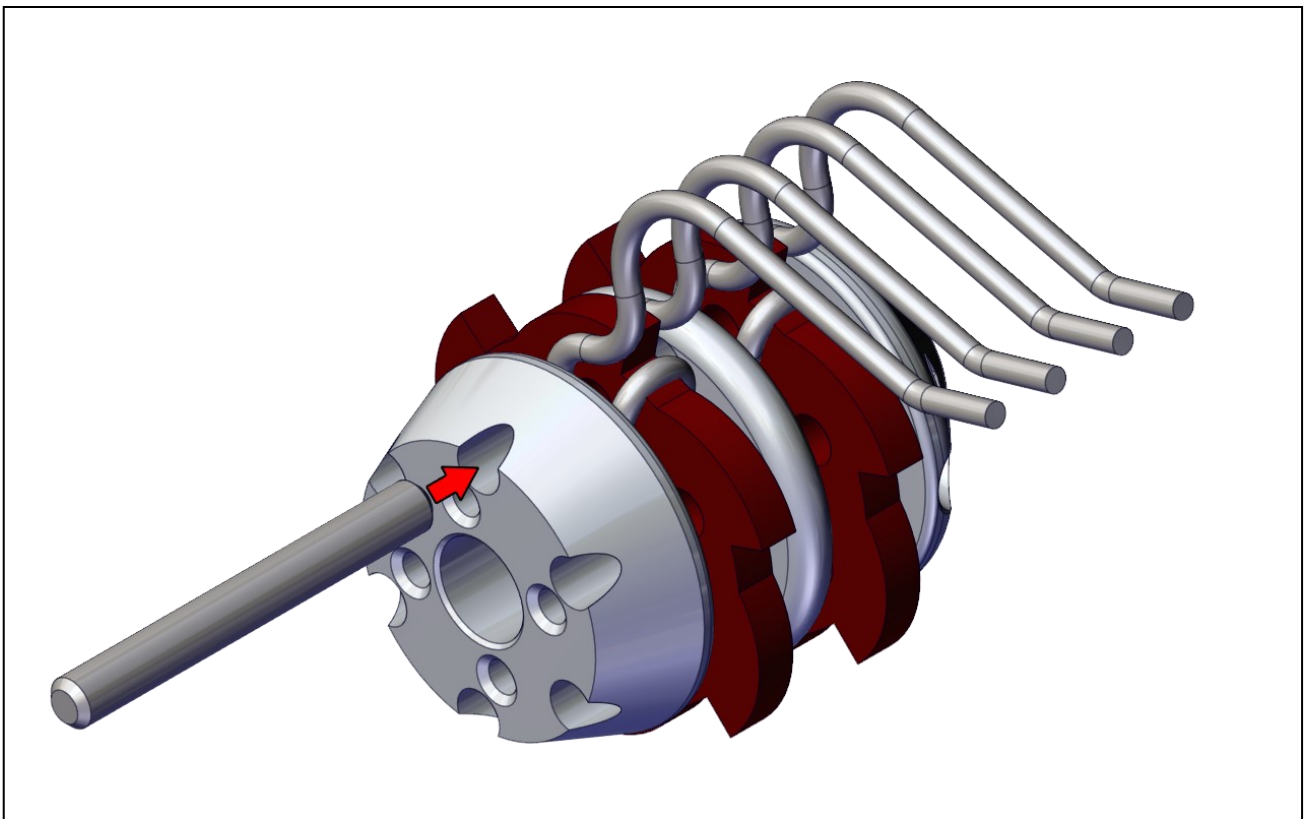

**Tool Change—Smart Spider DN100 (4") & DN150 (6")**



**Step 7.** Change all the Spider Legs accordingly.

Assemble the tool then by following the previous steps in opposite order.

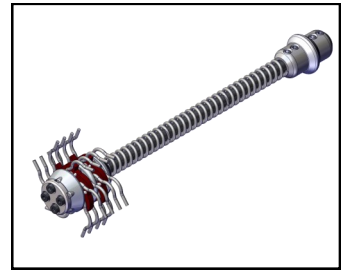

**Recommended to use Loctite 542.**

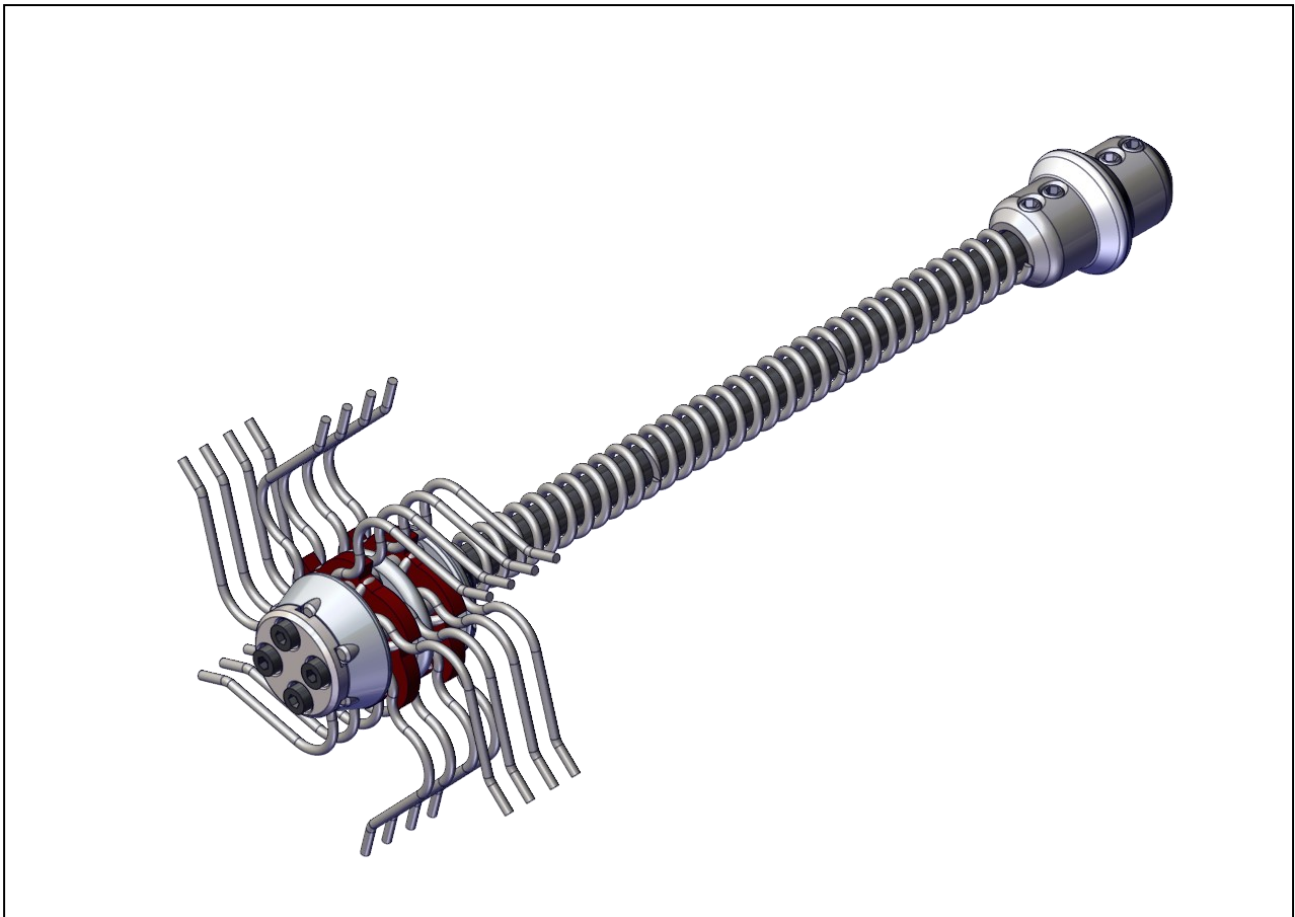

## Using the Smart Spider products



**NEVER POWER ON THE SMART SPIDER OUTSIDE OF THE PIPE! The tooling needs to fit completely inside the pipe before turning the power on and using the tool. Failure to comply could lead to serious injury or death.**

### Before starting work

Select the correct size tooling and drill head for your job. Ensure water is flowing in the pipe or the vacuum extraction is ready (dry cleaning). Ventilate the working area properly. Ensure that all metallic drain pipes are grounded/earthed. The Smart Spider causes high friction and there is risk of electric shocks. Using a CCTV camera verify the correct position to locate the Smart Spider. Place the Smart Spider inside the pipe ensuring that legs fit completely inside before turning the machine on.

### During use

Switch the power on. Initially start the Smart Spider at a low speed. Slowly increase the speed. Adjust the speed while working but do not exceed 50%, as the tool may get stuck. Hold the shaft tightly. Move the tool in back and forth movement in the pipe. Always use a CCTV camera to check how you are progressing.

Do not force the tool through the pipe—let the tool do the work. If too much force or excessive high speed is used the tool might get stuck resulting in damaging or breaking the tool, shaft or the pipe. Use either water or vacuum to remove the debris. Use lower speed when working in fragile or damaged sections of the pipe.



**Please note!** Smart Spider legs get very hot during use. Where water cooling is not being used, you need to take breaks to cool down the tool head after 10-15 min. Always wear heat resistant gloves after the machine has been switched off and the power supply isolated. The tools can then be cooled down using water or left to cool in the open air. Always observe the temperature of the outer casing and let the Miller cool down after every 30 min periods of constant work.

Please read safety information on page 3 before assembly and use.

## Using the Smart Spider products



### After use

**WARNING:** Turn the power off and isolate the supply before you remove the tool from the pipe. There is a risk of serious injury or death! **The tool can be very hot.** Carefully take the tool out from the pipe.

Check out the condition of the tooling and shaft. Replace worn-out parts. If shaft looks damaged, remove decrepit part with an angle grinder and shorten the outer casing accordingly.

Carefully inspect the Smart Spider Legs and when the straight part of the leg tip is worn to first angular change, all the legs should be replaced. At the same time of replacing the legs the Premium Rubber Flexes should be replaced.

### RECOMMENDATIONS

**Always use CCTV camera while working.**

**Adjust the rotation speed while working but never exceed 50% of rpm.**

**Use water cooling when possible.**

**Do not use excess amount of force to push the tooling. Let the tool do the work.**

**Afterwards use the Smart Cutter™ to ensure perfect finish.**

**To improve the efficiency and cut down work time you regularly need to change the Spider legs and the Premium Rubber Flexes.**

Please read safety information on page 3 before assembly and use.

# MAINTENANCE

## CARING FOR THE FLEXIBLE SHAFT

Prior to shipping the flexible shaft is pre-treated with **Picote Flexible Shaft Lubricant (1350000020)** and the outer casing replaced. Always inspect the condition and when required apply lubricant between the flexible shaft and its outer casing. If necessary remove the shaft from its casing to treat. When the casing has been replaced, manually rotate the shaft for even coverage.



## SMART SPIDER LEGS & RUBBER FLEXES

**Always replace** all of the Spider Legs and the Rubber Flexes at the same time. The correct time to change the Spider Legs is when the leg tip is worn to first angular change.

## FASTENER SCREWS

Replace the fastener screws immediately if you are unable to fully tighten them due to worn out hex socket heads. Otherwise, the tool could detach from the shaft during the use and fall into the pipe.



## HUB BOLTS

Use Thread Sealant (Loctite 542 or similar) when tightening bolts which secure the Spider Axles. Otherwise, the Smart Spider can fall into the pipe while working.

# SPARE PARTS

1390100001	Smart Spider DN100 (4") legs / spare parts
1390100002	Smart Spider DN150 (6") legs/ spare parts
1390100005	Smart Spider Premium Rubber Flex / spare parts
1390100004	Smart Spider axle / spare part

# TRAINING

For information about product training and support contact Picote Solutions or your authorized Picote reseller.

## PRACTICAL TIPS & SAFETY ADVICE

Here are some useful tips on how to get the most out of your Picote system. Always use the recommended tools for maintenance to avoid personal injury.



### CUTTING THE FLEXIBLE SHAFT



Always inspect the flexible shaft before each use. If there are potential weak points or the shaft is damaged, cut off the damaged length using a band saw.



### SHAFT ROUNDER



The shaft rounder smooths the end of the flexible shaft, preventing the user from being cut by the otherwise sharp metal edge.



### ATTACHING A SHAFT SOCKET



Feed the shaft through the socket to the end and **securely fasten**. The outer casing should reach all the way to the base of the shaft socket to protect the shaft.

### ADDING A VISUAL MARKER FOR SAFETY



Attach a visual marker (tape) to the outer casing of the flexible shaft. Place it around half a metre from the end point of the shaft. The mark will indicate the chain's location and prevent possible injuries when the Pipe Cutter is removed from the pipe, including injury by rotating parts.



### CREATING LEADERS

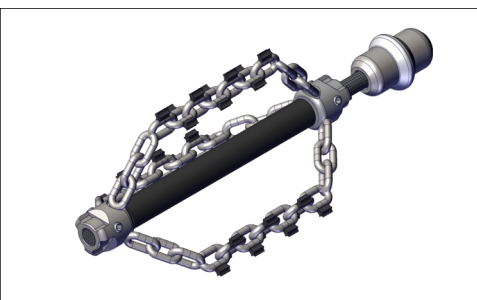

You can extend the life of the flexible shaft and increase productivity on site by making individual leaders for the most commonly used tools. This way you easily and quickly switch between tooling.

## WARRANTY POLICY AND PROCEDURE

### Limited Warranty:

Picote warrants to the original End User that the Product purchased by such End User will operate in accordance with and substantially conform to their published specifications when shipped or otherwise delivered to the End User and for a period of one (1) year, except electric motors for which the warranty period shall be six (6) months, provided, however, that Picote does not warrant any claim or damage under this

Warranty if such claim or damage results from:

1. Consumable parts or normal wear and tear resulting from use of the Products,
2. Product overload or overheated motor,
3. Regular periodic maintenance of Products,
4. Misuse, neglect, or improper installation or maintenance of the Products, or use of Products not for their intended purpose,
5. Products that have been altered, modified, repaired, opened or tampered with by anyone other than Picote or an authorized Picote Service Centre, or unsuitable or unauthorized spare parts, accessories or third party products when using the Products or;
6. the use of the Products not in compliance with their respective Documentation, user manuals, safety and maintenance instructions, and any usage restrictions contained therein, or
7. accident, fire, power failure, power surge, or other hazard.

Otherwise, the Products are sold AS IS. End User is responsible for using the Products within their specifications and instructions as contained in the Documentation.

**EXCEPT AS SPECIFIED IN THIS WARRANTY, ALL EXPRESS OR IMPLIED CONDITIONS, REPRESENTATIONS, AND WARRANTIES INCLUDING, WITHOUT LIMITATION, ANY IMPLIED WARRANTY OR CONDITION OF MERCHANTABILITY, FITNESS FOR A PARTICULAR PURPOSE, NONINFRINGEMENT, SATISFACTORY QUALITY OR ARISING FROM A COURSE OF DEALING, LAW, USAGE, OR TRADE PRACTICE, ARE HEREBY EXCLUDED TO THE EXTENT ALLOWED BY APPLICABLE LAW. TO THE EXTENT AN IMPLIED WARRANTY CANNOT BE EXCLUDED, SUCH WARRANTY IS LIMITED IN DURATION TO THE WARRANTY PERIOD. BECAUSE SOME STATES OR JURISDICTIONS DO NOT ALLOW LIMITATIONS ON HOW LONG AN IMPLIED WARRANTY LASTS, THE ABOVE LIMITATION MAY NOT APPLY. This disclaimer and exclusion shall apply even if the express warranty set forth above fails of its essential purpose.**

**Please Contact:**

Your Reseller / Salesperson or Picote

[www.picotesolutions.com](http://www.picotesolutions.com)



**International Offices**

Finland. United Kingdom. USA.

**Dawn Greig**

Global Business Development &  
Creative Director  
+44 7585116508  
[dawn@picotesolutions.com](mailto:dawn@picotesolutions.com)

**Anthony DeCavitch**

Global Sales Director  
+1 219 440 1404  
[tony@picotesolutions.com](mailto:tony@picotesolutions.com)

**Technical Support**

**Jake Saltzman**

World Wide Technical Director  
+1 706 436 1892  
[jake@picotesolutions.com](mailto:jake@picotesolutions.com)

**Richard Swan**

Director of Technical Client Services  
+44 (0)7827 223237  
[richard@picotesolutions.com](mailto:richard@picotesolutions.com)

**Production & R&D**

Raudoittajantie 4  
06450 Porvoo, Finland  
[support@picotesolutions.com](mailto:support@picotesolutions.com)

**Authorised Resellers:**

[www.picotesolutions.com/resellers](http://www.picotesolutions.com/resellers)